

# DOCTOR

**ICON**  
RESEARCH

## Portable Systems



### FEATURES

- Proven Reliability and Accuracy
- Cylinder Only and Combined Cylinder + Fuel/Vibration Versions Available
- Comprehensive Analysis Software
- Choice of Inductive or Optical Crank Synchronization
- Easy Carrying in Rugged Case

---

### Portable Doctor Systems

The portable Doctor DK-2 series is an industry standard for cylinder pressure measurement, having built its reputation on reliability, accuracy and ease-of-use. The "Diesel Doctor", as it is often known, is housed in an extremely rugged plastic case and is fully seal against moisture and dirt. A complete system, including sensors and cables, fits into a convenient shoulder bag about the same size as a camcorder case.

Two versions are available. The DK-2 is a single channel unit for measuring cylinder pressure while the DK-2/FV measures cylinder and fuel pressure or vibration traces simultaneously. Both systems use Kistler pressure sensors for long-term reliability and accuracy.

### System Description

For synchronizing to shaft rotation, two schemes are available. The first uses an inductive pickup that senses a small metal target on the flywheel. This can be permanently wired to a junction box on the engine. This enables straightforward connection of a cable for quick speed and shaft synchronization. For large 2-stroke engines a dual pick-up system is available that compensates for changes in rotational speed during each revolution of the engine. This provides increased accuracy when the



engine is, for example, driving a propeller shaft directly.

The second scheme is ideal for service work and comprises an optical pickup with a small fibre-optic extension. This will sense any light-colored marker on the flywheel. It is often possible to use an existing mark and so it is not necessary to stop the engine before taking a set of readings.

Operation of the system is simple. The engine configuration (2-stroke/4-stroke, V/inline, etc) is entered and this is stored under the engine name. Hence, this is a "once-only" task. To take a measurement, the operator connects the pressure and vibration sensors to the appropriate

cylinder, and presses the GO button on the Engine Processor Unit (EPU). The screen indicates the progress of the measurement and, once complete, the operator just moves the pressure sensor to the next cylinder and presses GO again. Key parameters such as power, angle of Pmax, etc. are shown on the screen. The system is easily operated by one person, and the

time to measure a typical engine is just ten minutes or so.

Once all cylinders have been measured, results are transferred to a PC via the serial port on the unit. The detailed graphs and full analysis options of the standard Doctor software are then available to examine results.

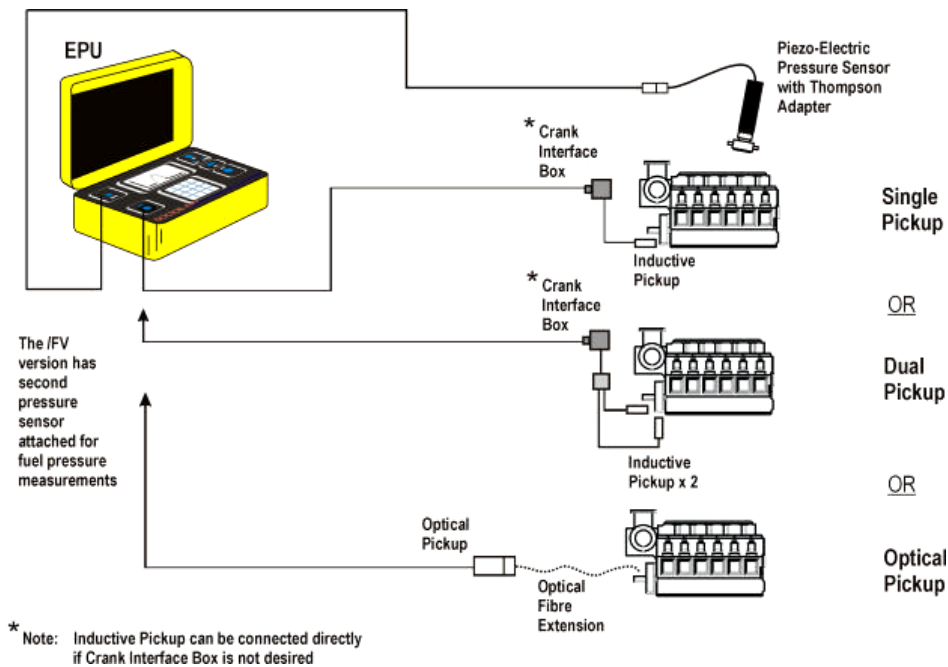

#### ENGINE PROCESSOR UNIT:

Power: 100V to 240Vac  
 Memory: Up to 105 cylinder results  
 Display: LCD Screen  
 Keypad: Flexible Rubber type  
 Sealing: IP66 (IP67 with lid closed)  
 Operating Temp: -10°C to 55°C  
 Weight: 4.5kg  
 Link to PC: RS232 @ 9600 baud

#### CYLINDER PRESSURE SENSOR:

Type: Piezo-Electric  
 Adapter: Standard Thompson Adapter  
 Power: Supplied from EPU  
 Operating Temp: 350°C max at sensor element  
 Extension Cable: Fischer to TNC  
 Length: 5m  
 Sensitivity (Typ): 20mV/bar

#### FUEL PRESSURE SENSOR:

Type: Piezo-Electric  
 Adapter: Threaded Adapter  
 Power: Supplied from EPU  
 Operating Temp: 200°C max at sensor element  
 Extension Cable: Fischer to TNC  
 Length: 5m  
 Sensitivity (Typ): 20mV/bar

#### VIBRATION SENSOR:

Type: Accelerometer (Piezo-Electric)  
 Power: Supplied from EPU  
 Length: 5m  
 Sensitivity (Typ): 100mV/g

#### Certified Reseller / Service Specialist:

**IMPACT Engineering Inc**  
 6716 Eastside Drive NE, Suite 6  
 Tacoma, WA  
 Tel: (253) 942-9000  
 Fax: (253) 942-9009  
[www.impactengineering.com](http://www.impactengineering.com)